

**NETWORK INTERFACE BOARD**  
**(Machine Code: G919)**

# 1. OVERALL MACHINE INFORMATION

## 1.1 SPECIFICATIONS

Item	Specification
Type	Internal Network Interface Board
Network Topology	Ethernet (10 Base-T) and Fast Ethernet (100 Base-TX)
Network Interface	RJ45 x 1
Protocols	IPX, TCP/IP, EtherTalk
SNMP Support	<ul style="list-style-type: none"> <li>• IP and IPX SNMP support of MIB-2 and proprietary NIC MIB.</li> <li>• SNMP support of standard MIB and proprietary printer MIBs on compatible printers.</li> </ul>
Required Cable	STP (Shielded Twisted-Pair) cable Category/Type 5 or better <b>Note:</b> A cable is not enclosed with this option.
Utility Software	<ul style="list-style-type: none"> <li>• MAP (Management Access Protocol)</li> <li>• IPX peer-to-peer printing</li> <li>• IP peer-to-peer printing</li> <li>• BOOTP (16-bit and 32-bit)</li> <li>• NetWare setup utility</li> </ul>
Other	<ul style="list-style-type: none"> <li>• Built-in web server</li> <li>• Built-in Telnet server</li> <li>• Firmware update over an IPX or IP network</li> </ul>

---

## 2. INSTALLATION PROCEDURE

### 2.1 HARDWARE INSTALLATION

Refer to the base engine or printer controller installation instructions for how to install the network interface board.

#### 2.1.1 SERIAL NUMBER AND MAC ADDRESS

Check the serial number and MAC (Media Access Control) address that are printed on the network interface board (NIB).

The serial number is a 6-digit number, and is unique to each board.

The MAC address (LAN ADDR.) is a 12-digit hexadecimal number. The upper 6 digits are always "0040AF", and the lower 6 digits are unique to each board.

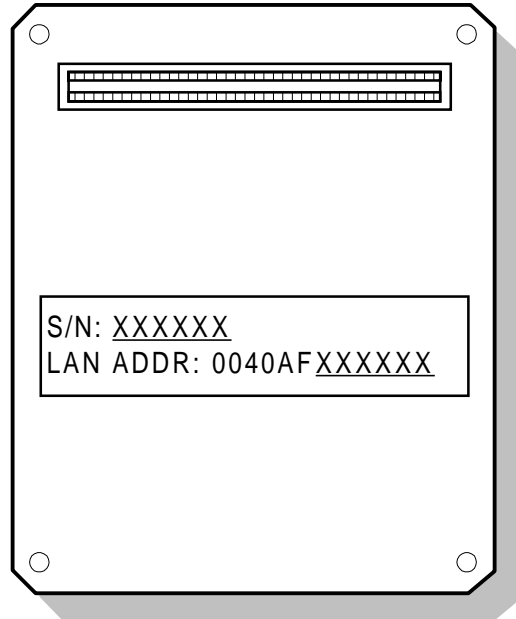

G919I500.WMF

#### 2.1.2 STATUS SHEET

By default, the NIB (network interface board) prints a status sheet every time after the machine is turned on or the NIB has reset itself.

**NOTE:** Connect a network cable to the NIB before turning on the machine or resetting the NIB. Otherwise, the machine will take several minutes to print the status sheet, and the information on it may not be accurate.

Keep the status sheet with the machine, because it has the following information.

- Unit serial number
- Firmware version
- Network (MAC) address
- Network/Protocol information

## 2.2 PROGRAMMING NETWORK/PROTOCOL PARAMETERS

This section gives summaries of how to set up a network interface board in various network environments.

**NOTE:** It is not recommended for service technicians to program network and protocol parameters. Ask the customer's network administrator to program and manage these parameters.

### 2.2.1 IPX NETWORK

The following parameters are required for three types of IPX network printing. Use MAP (Management Access Program) or the NetWare Setup utility to program these parameters.

**NOTE:** 1) The MAP utility requires the Microsoft IPX/SPX Compatible protocol stack on Windows 9x or Windows NT4.0, and a Web browser (Microsoft Internet Explorer 3.02 or later, or any version of Netscape Navigator). The "World Wide Web Publishing" service must be stopped before starting the MAP utility on the Windows NT server desktop.  
2) The NetWare Setup Utility requires the Novell 32-bit Client software on Windows 9x or Windows NT4.0.

Parameter	Peer-to-Peer Serverless Network	Novell 2.x/3.x/4.x Bindery Network	Novell 4.x NDS Network
Enable NetWare (Default = Yes)	Yes (Check the box)	Yes (Check the box)	Yes (Check the box)
Print Server Name	Yes	Yes	Yes
Print Server Password	No	Optional	Optional
Preferred File Server	No	Yes	No
Preferred NDS Context	No	No	Yes
Preferred NDS Tree	No	No	Yes
Print Queue Scan Rate (Default = 1 s)	No	Yes	Yes
Ethernet Frame Type (Default = Auto-Sense)	Yes	Yes	Yes
Disable Bindery (Default = No)	No	No (Uncheck the box)	Optional

**NOTE:** The preferred NDS context must be typed in without a starting dot ( . ).

- OU=Development.O=Corp [OK]
- .OU=Development.O=Corp [NG]
- Development.Corp [OK]
- .Development.Corp [NG]

n

## 2.2.2 TCP/IP NETWORK

### *TCP/IP Parameter Details*

The following TCP/IP parameters are required for TCP/IP network printing.

Parameter	Description	How to Change Parameters		
		Operation Panel/ BOOTPL	MAP/Web Browser	Telnet
<b>IP Parameters</b>				
IP Address	IP address of the NIB	Yes	Yes	Yes
Subnet Mask	Subnet mask for local subnet	Yes	Yes	Yes
Default Gateway	Gateway IP address	Yes	Yes	Yes
<b>TCP Parameters</b>				
Base Port Number	Port number to receive print jobs	No	Yes	Yes
<b>DHCP Parameters</b>				
Enable DHCP (Default = Yes)	<b>Yes</b> – The NIB obtains IP parameters from a DHCP server. <b>No</b> – IP parameters must be specified manually.	No	Yes	No
IP Address in NVRAM (Default = Yes)	<b>Yes</b> – Once the NIB has been assigned an IP address by a DHCP server, the NIB saves the address in the NVRAM and uses it permanently. <b>No</b> – The NIB tries to obtain IP parameters from a DHCP server every time the machine is turned on or the NIB is reset. The assigned IP address may not be the same every time.	No	Yes	No
<b>LPD Parameters</b>				
Enable LPD Banner (Default = No)	Enables or disables the LPD banner	No	Yes	Yes
Available PDLs for NIC Port	Available printer languages are automatically selected.	No	Yes	Yes

### ***Possible Problems with DHCP Parameter Settings***

1. IP address conflicts with another host  
If DHCP is enabled and an IP Address is saved in NVRAM, and the saved address conflicts with another host, the NIB does not show any errors. As a result, the NIB cannot receive any print jobs, because the IP protocol is disabled automatically at startup.

In this case, the other host in conflict with the NIB must have a manually assigned IP address. Find the host using the ping and arp commands for example, and assign a correct address.

2. IP address changes after restarting the machine  
If DHCP is enabled but an IP address is not saved in the NVRAM, the NIB may have a different IP address from the one before restarting the machine. As a result, the NIB cannot receive any print jobs, because the jobs are sent to the previously assigned IP address.

There are two solutions for this problem.

The first one is simply enable the "IP Address in NVRAM" parameter and assign a correct IP address. The second one is to reserve the IP address on the DHCP server for the NIB's Ethernet (MAC) Address.

### **2.2.3 ETHERTALK (APPLETALK) NETWORK**

The following parameters are required for AppleTalk networks. These parameters are automatically configured at startup as follows:

<b>Parameter</b>	<b>Default Setting</b>	<b>How to change the parameter</b>
AppleTalk Enable/Disable	Enabled	MAP, web browser and telnet.
Printer Name	Plug&Play name	See Note.
Zone Name	Default zone	See Note.

- NOTE:**
- 1) The Apple LaserWriter utility can change both the printer name and the zone name. The Apple Printer Utility can change the printer name only.
  - 2) Even if the printer name and zone name are changed with a utility, the changed names will be reset to the defaults at the next power-on, due to NIB-to-Controller interface limitations.

## 2.3 SETUP FOR VARIOUS NETWORK TYPES

### 2.3.1 PEER-TO-PEER NETWORK

#### *Windows for Workgroups*

There is no guaranteed way to print directly to the NIB port. Share a printer connected to an LPT port on a workstation.

#### *Windows 95/98*

The Peer-to-Peer IPX and the Peer-to-Peer IP utilities install redirection to the NIB.

The Peer-to-Peer IPX port appears as "RDP\_XXXX" (XXXX is the board's serial number) by default.

The Peer-to-Peer IP port appears as "IP Address (10001)".

Both work as a local port of the host computer.

#### *Windows NT (Workgroup Network)*

In addition to Peer-to-Peer IPX and Peer-to-Peer IP printing, Windows NT supports LPR printing using TCP/IP protocol.

Use the following parameters to set up an LPR port on an NT workstation.

- Name or address of the server providing lpd: IP Address of the NIB
- Name of the printer or print queue on that server: PORT1 (uppercase)

After installing a printer connected to the LPR port, share the printer for other workgroup members.

## 2.3.2 NOVELL NETWARE NETWORK

### *Bindery Network*

Use the NetWare Setup utility to set up everything for NetWare printing in a single procedure.

Or, use PCONSOLE to set up printers, print queues, and print servers in the server bindery, then use MAP (Management Access Program) to setup NetWare parameters in the NIB.

**NOTE:** 1) The NetWare Setup utility requires Novell 32-bit client on Windows 9x or NT. Also, supervisor privileges are required to do the complete setup.  
2) The MAP utility requires the Microsoft IPX/SPX SPX compatible protocol stack on Windows 9x or Windows NT4.0, and a Web browser (Microsoft Internet Explorer 3.02 or later, or any version of Netscape Navigator ).

### *NDS Network*

Use the NetWare Setup utility to set up everything for NetWare printing in a single procedure.

Or, use PCONSOLE or NetWare Administrator to set up printers, print queues, and print servers in the server bindery, then use MAP (Management Access Program) to set up NetWare parameters in the NIB.

**NOTE:** The NIB does not support the "Notification" function on NetWare NDS networks.

## 2.3.3 TCP/IP NETWORK

### *LPR/LPD Printing*

The NIB supports standard lpd. If a Windows or UNIX workstation has an lpr spooler, it can send print jobs to the NIB directly.

### *FTP Printing*

This printer does not support FTP printing.



### 3. SERVICE TABLES AND PROCEDURES

#### 3.1 FACTORY RESET (NVRAM CLEAR)

When the machine or the network interface board has moved to a different location, reset the NVRAM contents to the factory defaults as follows.

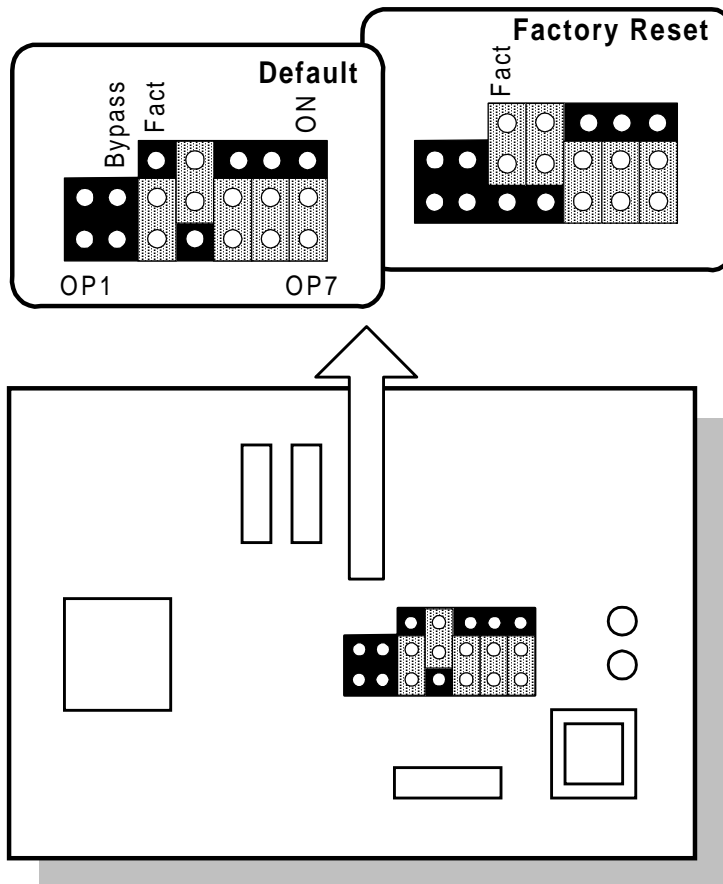

G919M500.WMF

1. Remove the network interface board and the NIB cover (4 screws). Then change the FACT jumper setting as shown above.
2. Install the network interface board and turn on the machine.
3. The green LED flashes 3 times, then the amber and green LEDs light alternately (once per second).
4. Turn off the machine and remove the network interface board.
5. Reset the jumper setting to the default, and reassemble the machine.
6. Turn on the machine.

## 3.2 FLASH ROM UPDATE

### 3.2.1 INTRODUCTION

Before you update network interface card firmware, you need to receive the latest firmware file and set up an update utility that is suitable for the network environment.

A firmware file (\*.upd, \*.upp, \*.upt, or \*.upu file) is normally distributed as a ZIP file (e.g., RIC221.ZIP). The update procedure is the same for each of these file types. Before starting the firmware update utility, you need to unzip the file to a temporary directory on a host computer.

Two types of utility software, FlashUP and FTPDL, are provided as ZIP files with this document. Use the FlashUP utility for Novell server based IPX networks, or use the FTPDL utility for TCP/IP networks. You do not need to install both because they have the same function.

**NOTE:** Before using the FTPDL utility, the NIB must be configured with an IP address and subnet mask.

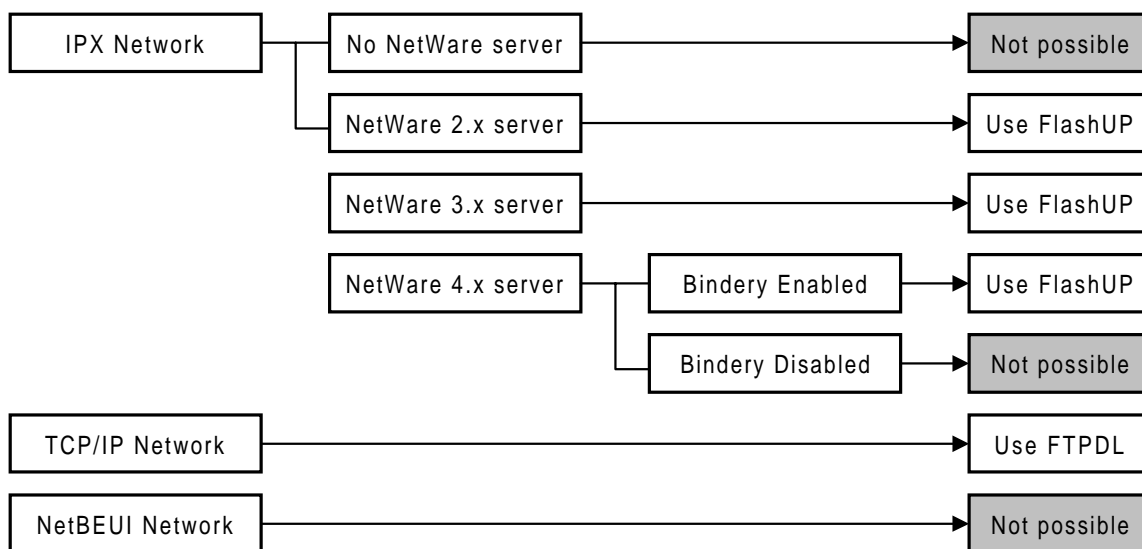

G919M501.WMF

### 3.2.2 FLASHUP UTILITY (FOR NOVELL IPX NETWORKS)

#### **System Requirements**

- Windows 3.1x/95/98, Windows NT3.5x/4.0
- Novell compatible IPX protocol installed
- Novell compatible NetWare client software installed

#### **Network Requirements**

- NetWare 2.x/3.x/4.x server running in Bindery mode

#### **Installation Procedure**

1. Unzip Flash\_up.ZIP to a temporary folder (directory). The following files should be extracted there.

#### **FLASH\_UP.ZIP**

File size	Date	Time	Name
280,481	07-10-96	02:15:12	_INST16.EX_
8,192	09-07-95	20:22:40	_ISDEL.EXE
238,568	11-10-98	13:46:00	_SETUP.1
5,984	04-29-96	08:25:22	_SETUP.DLL
156,070	11-10-98	13:45:52	_SETUP.LIB
5	11-10-98	13:46:00	DISK1.ID
686	11-06-98	08:54:26	Readme.txt
44,608	07-24-96	04:00:00	SETUP.EXE
33	11-10-98	13:45:54	SETUP.INI
64,864	07-31-96	12:50:10	SETUP.INS
392	11-10-98	13:45:50	SETUP.ISS
166	11-10-98	13:45:58	SETUP.PKG
800,049 bytes			12 files

2. Run "Setup.exe" from the folder (directory).
3. Click "Next >" in the "Welcome" dialog box.
4. Read the readme.txt file displayed in the "Readme Information" dialog box, then click "Next >".
5. In the "Destination Location" dialog box, choose a folder (directory) to install the software, then click "Next >".
6. Confirm the program folder (group) name, then click "Next >".
7. After the software has been installed, click "Finish" in the "Setup Complete" dialog box.

**Firmware Update Procedure**

1. Login to the NetWare network as “supervisor” or a user with supervisor privileges.
2. Start the FlashUP utility.



3. Choose a new firmware file and click “OK”.

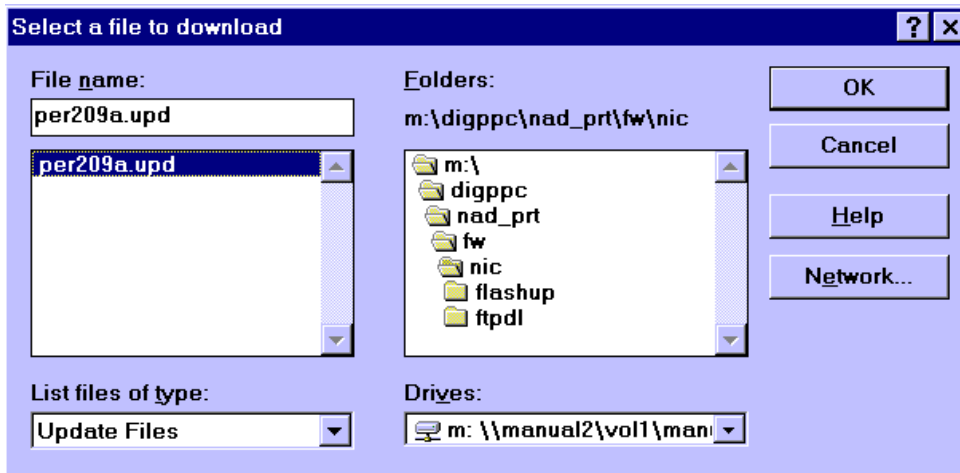

4. Choose a network interface card (or multiple cards) from the unit names listed in the dialog box, then click “OK”. The update will start.

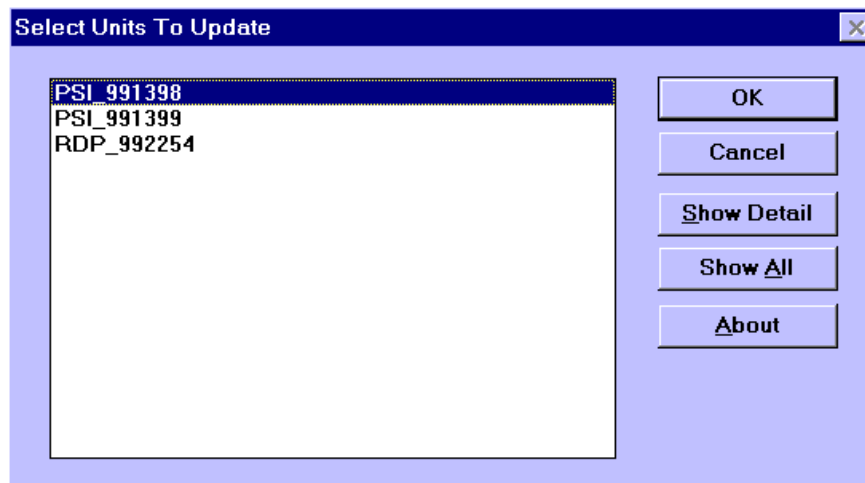

5. If you do not see the desired unit in the list, click “Show All” to display all network interface cards that are currently logged in to the server. If you still cannot see the unit, click “Cancel”, restart the machine (printer), and try again.

Options

6. After the firmware has been [downloaded](#) successfully, the following message pops up. Then click "OK" to finish.

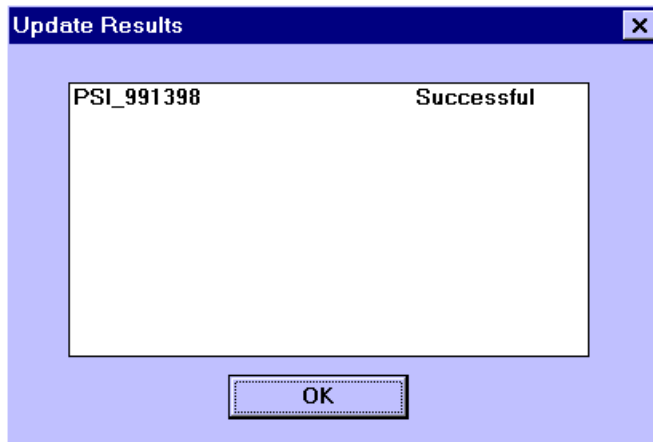

7. The Print Server Card then updates its flash ROM. The machine will print a status report after flash ROM update has finished.

**CAUTION:** Do not turn off the machine until after it prints a status sheet (after automatic re-initialization). Otherwise, new firmware may not be programmed to the flash ROM successfully.

### ***Recovery from Failed Download***

Even if firmware download has failed, firmware download is still possible.

The NIB in "down" status appears as DWN\_xxx\_xxxxxx in the dialog box in step 4 above. Download the firmware again to the NIB in "down" status using the FlashUp utility.

### 3.2.3 FTPDL UTILITY (FOR TCP/IP NETWORKS)



#### System Requirements

- Windows 3.1x/95/98, Windows NT4.0
- TCP/IP protocol installed

#### Network Requirements

- The target network interface board (NIB) must have a valid IP address.

**NOTE:** If the NIB is in the “DOWN” status, this utility cannot be used because no IP address is assigned to the NIB. Use the “Flashup” utility instead.

#### Installation

1. Unzip ftpdl.ZIP to a temporary folder (directory). The following files should be extracted there.

#### FTPDL.ZIP

File size	Date	Time	Name
280,481	07-10-96	02:15:12	_INST16.EX_
8,192	09-07-95	20:22:40	_ISDEL.EXE
668,293	12-21-98	16:52:20	_SETUP.1
5,984	04-29-96	08:25:22	_SETUP.DLL
156,374	12-21-98	16:52:06	_SETUP.LIB
5	12-21-98	16:52:20	DISK1.ID
1,146	12-21-98	16:50:54	Readme.txt
44,608	07-24-96	04:00:00	SETUP.EXE
33	12-21-98	16:52:10	SETUP.INI
64,864	07-31-96	12:50:10	SETUP.INS
391	12-21-98	16:52:04	SETUP.ISS
226	12-21-98	16:52:20	SETUP.PKG
-----			-----
1,230,597 bytes			12 files

1. Run “Setup.exe” from the folder (directory).
2. Click “Next >” in the “Welcome” dialog box.
3. Read the readme.txt file displayed in the “Readme Information” dialog box, then click “Next >”.
4. In the “Destination Location” dialog box, choose a folder (directory) to install the software, then click “Next >”.
5. Confirm the program folder (group) name, then click “Next >”.
6. After the software has been installed, click “Finish” in the “Setup Complete” dialog box.

### Firmware Update Procedure

1. Start the FTPDL utility.

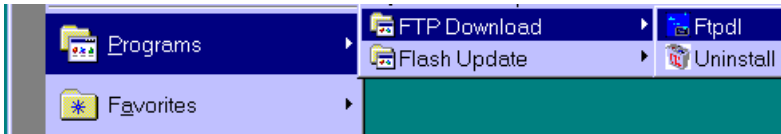

2. Choose [File] - [Download].

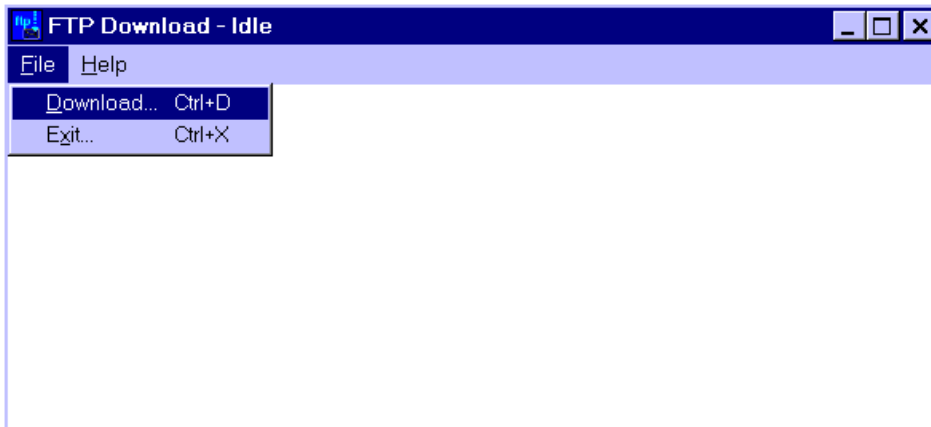

3. Choose a new firmware file and click "OK".

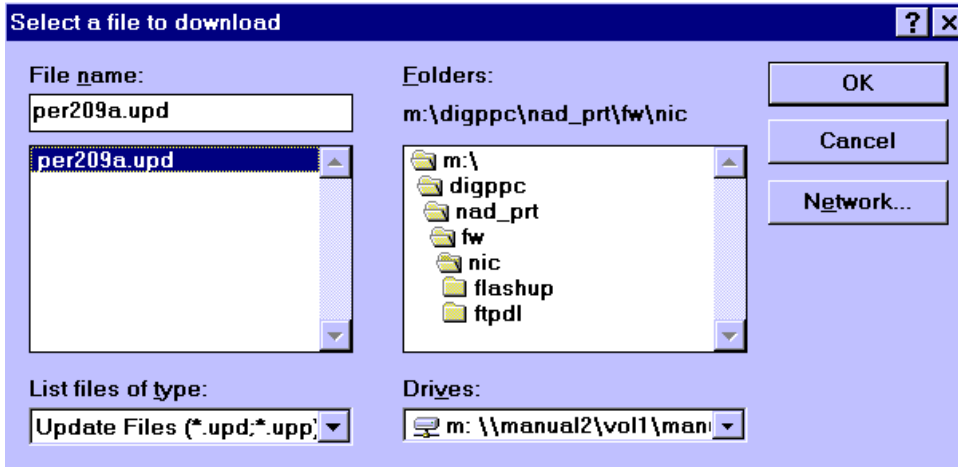

4. Enter the IP address of the network interface card in which you wish to update the firmware, then click "OK".

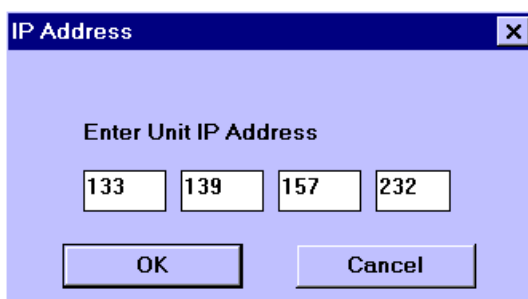

- Enter the password programmed in the network interface card ("sysadm" is the default), then click "OK".

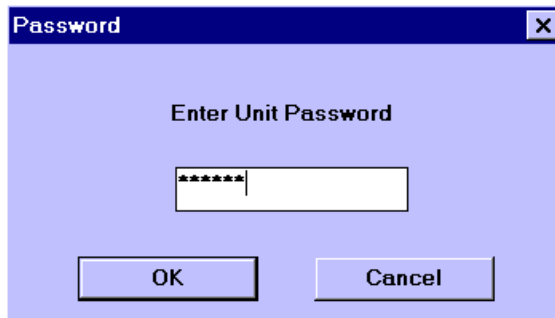

- After sending the flash ROM image file to the network interface card, the card updates its firmware.

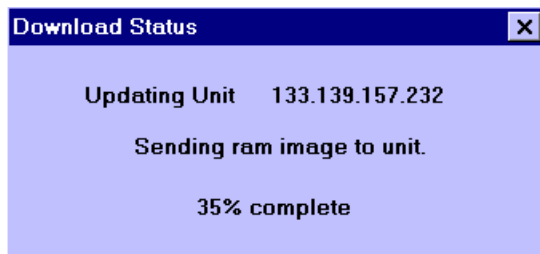

- After the firmware has been downloaded, click "OK" to finish.



- The Print Server Card then updates its flash ROM. The machine will print a status report after the flash ROM update has finished.

**CAUTION:** Do not turn off the machine until after it prints a status sheet.

### ***Recovery from Failed Download***

If firmware download using FTPDL has failed, use the FlashUP utility to recover the NIB. This is because the NIB may not have IP parameters anymore after a failed download.



## 4. TROUBLESHOOTING

### 4.1 LED INDICATIONS

Two LEDs visible from the outside, one amber and one green, indicate the status of the network interface board (NIB). Refer to the diagram on the right for their location.

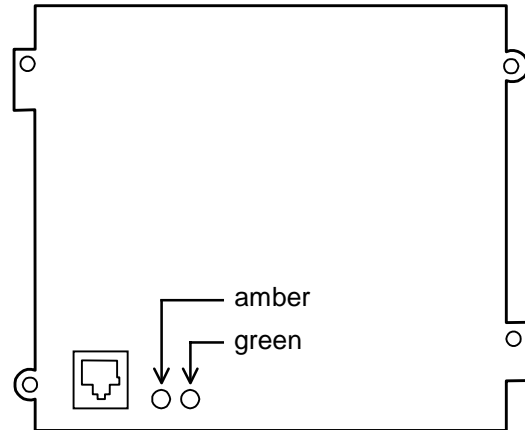

G919T500.WMF

Amber (left)	Green (right)	Status	Condition(s)
Blinks	On	Normal	<ul style="list-style-type: none"> <li>The NIB is receiving a packet from the Ethernet.</li> </ul>
---	On	Normal	<ul style="list-style-type: none"> <li>The machine has just been turned on. The NIB then initializes itself.</li> <li>The NIB is waiting for a print job.</li> </ul>
---	Blinks 3 times, then stays on	Normal	<ul style="list-style-type: none"> <li>The NIB has finished initialization, and will print a status sheet.</li> </ul>
---	Blinks rapidly	Initialization Error	<ul style="list-style-type: none"> <li>The NIB detected a bad RAM chip during initialization.</li> <li>Turn the machine off and on. If the NIB detects the same error again, replace the NIB.</li> </ul>
Blinks for 10 s, then goes off	Blinks	Initialization Error	<ul style="list-style-type: none"> <li>The NIB detected a data error in the flash ROM (firmware) during initialization.</li> <li>Recover the firmware by downloading it through the network.</li> </ul>
---	Blinks rapidly 4 times, then off	Error	<ul style="list-style-type: none"> <li>The NIB detected an Ethernet hardware error.</li> <li>Check the Ethernet connections and restart the machine. If the error is frequent, try replacing the NIB.</li> </ul>
---	Blinks rapidly	Error	<ul style="list-style-type: none"> <li>The NIB has lost connection to the NetWare file server(s).</li> <li>Check the cable connection and the NetWare server status.</li> </ul>
Blink alternately		NVRAM reset	<ul style="list-style-type: none"> <li>The NIB has reset its NVRAM to the factory defaults. (Refer to section 3.1 for how to reset the NVRAM.)</li> </ul>